

Chip Conveyor

Assembling and dismantling of the chip conveyor

INDEX MS16-6
INDEX MS16-6Plus

Control System INDEX C200-sl

Note on applicability

Illustrations in this publication may deviate from the product supplied. Errors and omissions due to technical progress expected.

A word on copyright

This document is protected by copyright and was originally compiled in German.

The duplication and distribution of this document or parts thereof is prohibited without prior consent of the copyright owner, and any violators will be prosecuted. All rights, including the right to translate, are reserved.

© Copyright by INDEX-Werke GmbH & Co. KG

Contents

Contents	3
Assembling and dismantling of the chip conveyor	4
Dismantling of the chip conveyor	4
Re-attachment of chip conveyor at the machine.....	7

Assembling and dismantling of the chip conveyor

Basically, it is not necessary to disassemble the chip conveyor of the MS16C machine for transport. For some types of work, however, it may be necessary to disassemble the chip conveyor and to mount it again afterwards. The respective procedure for this is described below.

Pos.	Designation	INDEX article number
①	Counter nut (2x)	415610.12
②	Attachment screw (2x) with washer (2x)	410260.1280 & 419010.12
③	Cover	M90031.20
④	Attachment screw (2x)	410261.1280
⑤	Washer (2x)	419021.16
⑥	Washer (2x)	419021.12
⑦	Leak oil drainage in the drag	–
⑧	Sealing screw	410773.0050

Dismantling of the chip conveyor

In order to be able to pull the chip conveyor out of the machine, a free space of approximately 1.5 m is required to the left and the chip conveyor must be disconnected from the coolant lubricant cleaning system. (Caution: coolant lubricant may be leaking!).

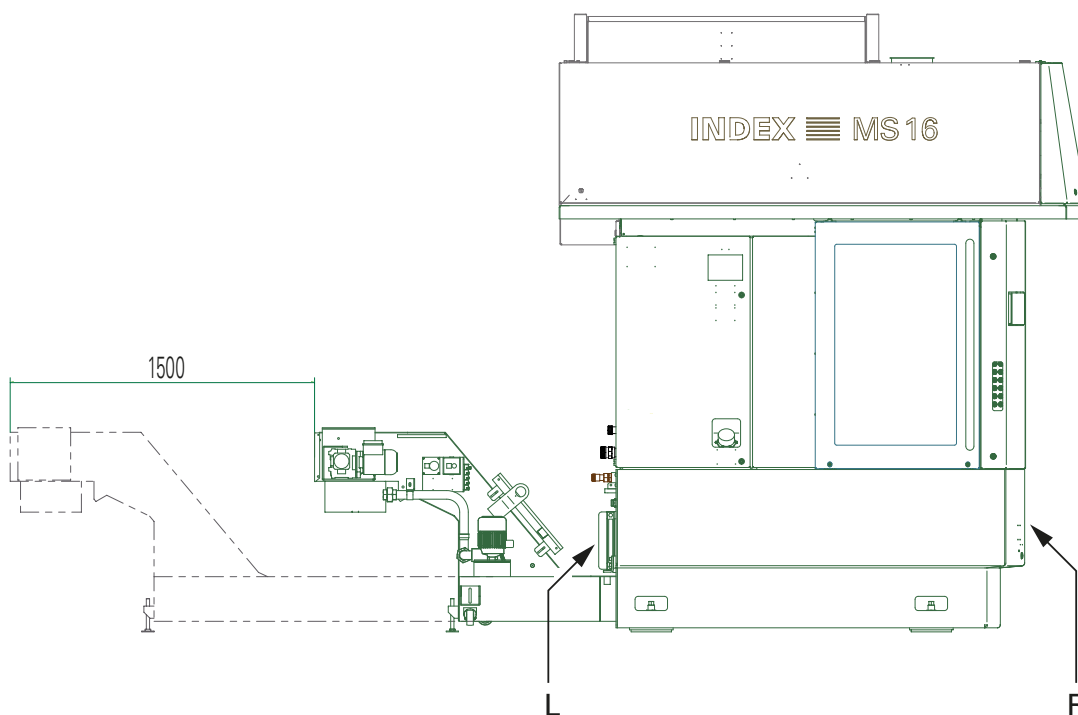

L = drag - left side
R = drag - right side

At the left side of the drag: Unfasten counter nuts ① of the attachment screws ② of the chip conveyor and unscrew attachment screws ②.

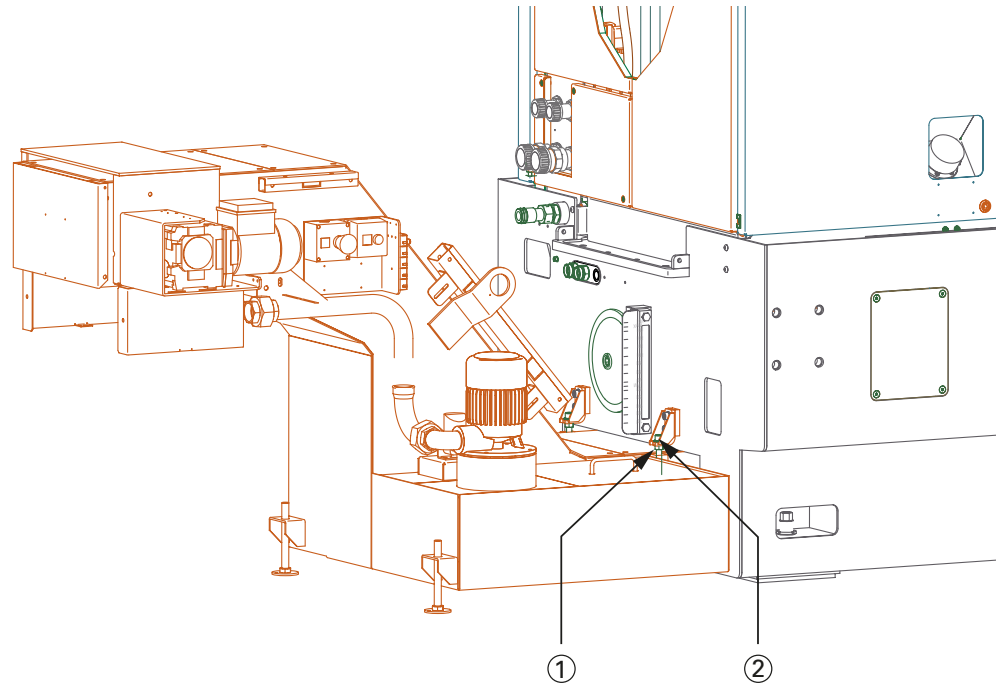

At the right side of the machine: dismantle cover ③ at drag.

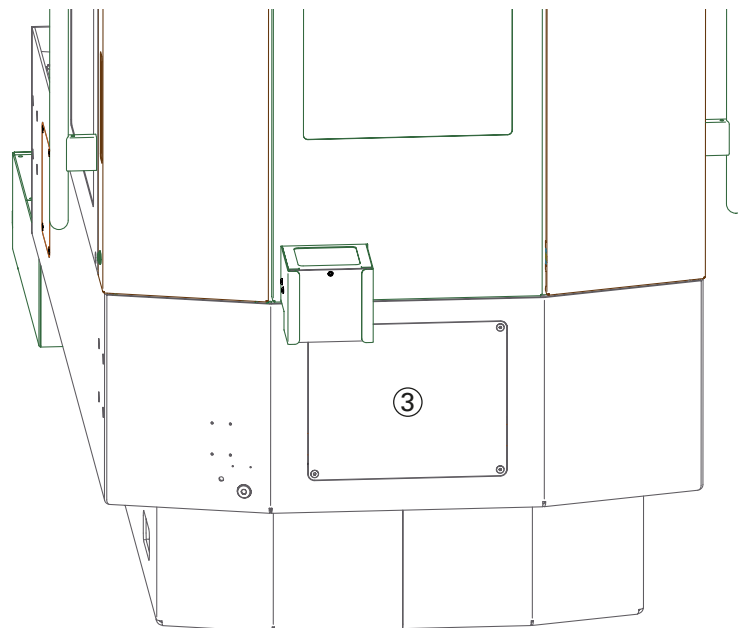

Thereafter, you can remove the two attachment screws ④ of the chip conveyor.

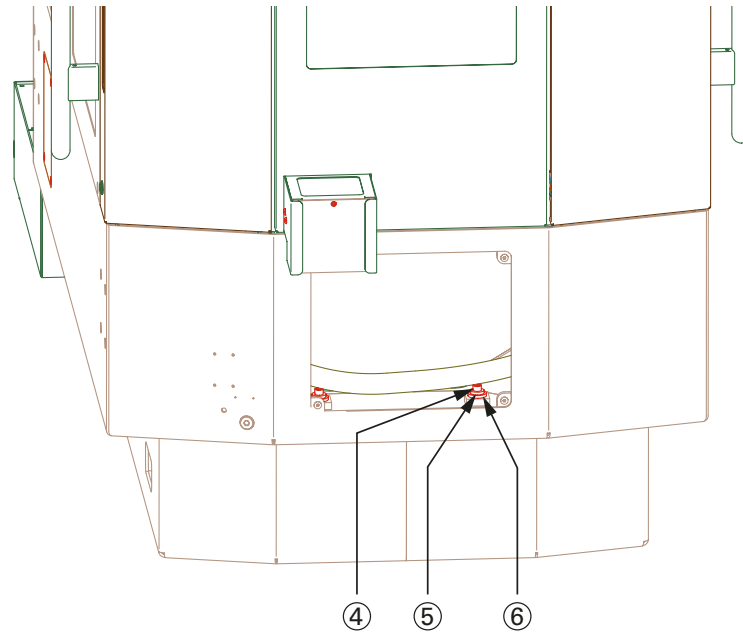

Thereafter, pull the chip conveyor out of the drag to the left-hand-side.

Seal the leak oil drainage boring ⑦ in the drag by means of the appropriate sealing screw ⑧.

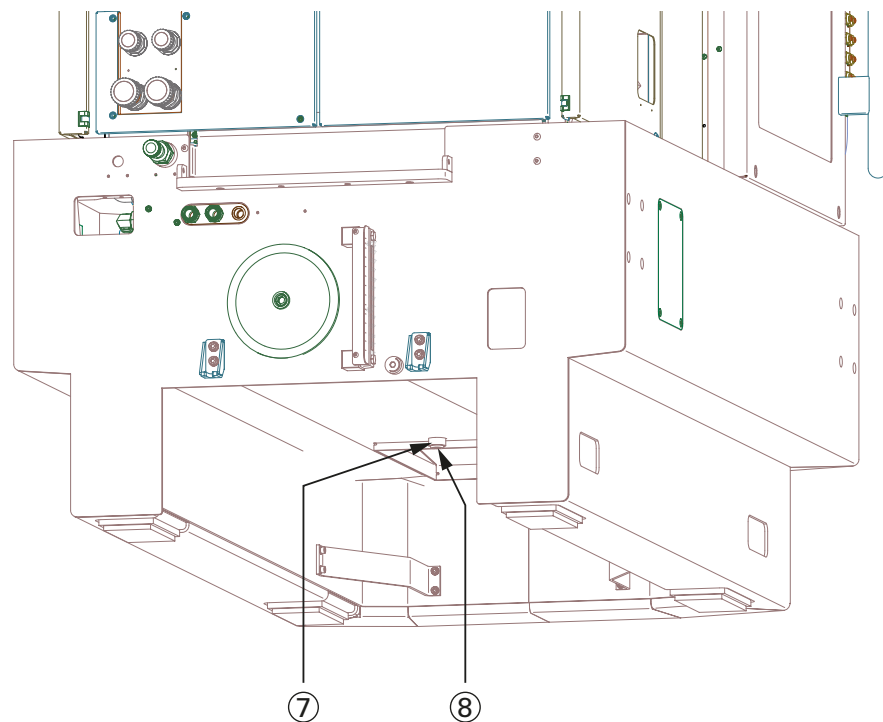

Re-attachment of chip conveyor at the machine

Remove sealing screw ⑧ from leak oil drainage boring ⑦ in the drag

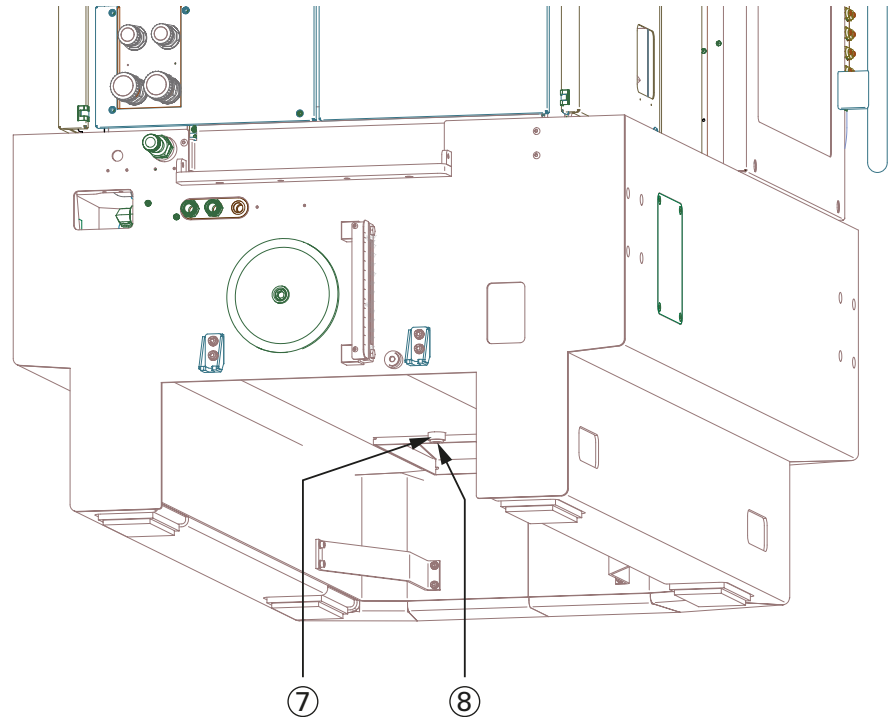

Push chip conveyor into the drag until limit stop .
At the right side of the drag: dismantle cover ③ at drag.

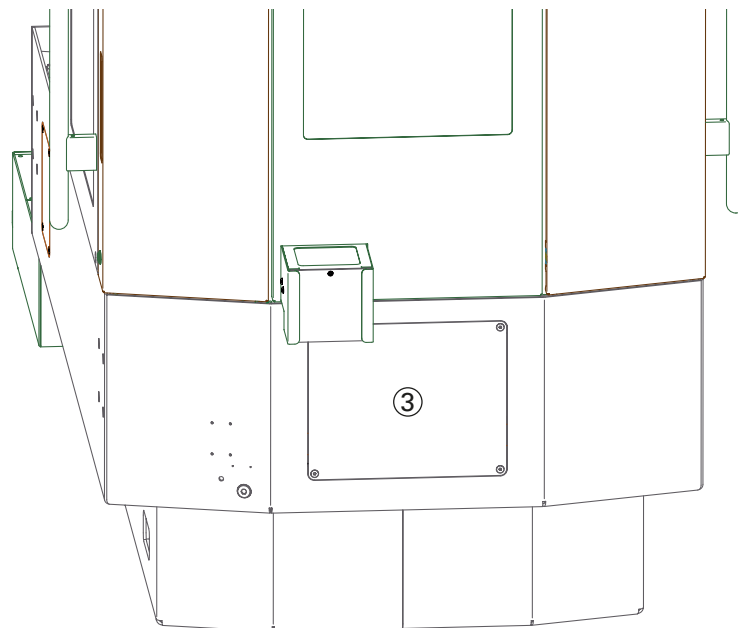

Put the attachment screws ④ of the chip conveyor plus respective washers ⑤ and ⑥ into the appropriate borings of the drag.

Attach chip conveyor to drag cautiously and evenly by means of said two screws ④. At this, fasten screws ④ slightly hand-tight.

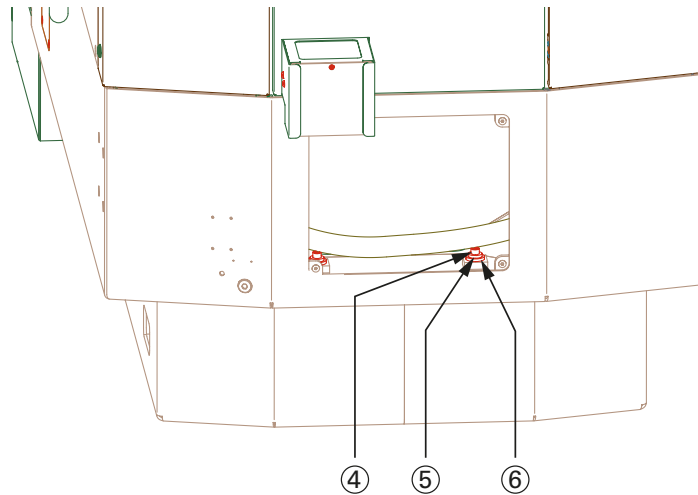

At the left side: Mount the two attachment screws ② plus respective washers and counter nuts ① and by means of same, adjust chip conveyor horizontally.

Thereafter, fasten the two screws ④ on the right side by means of a torque spanner at 35 Nm.

Check alignment of the chip conveyor once again and maybe correct by means of the attachment screws ② on the left side of the drag.

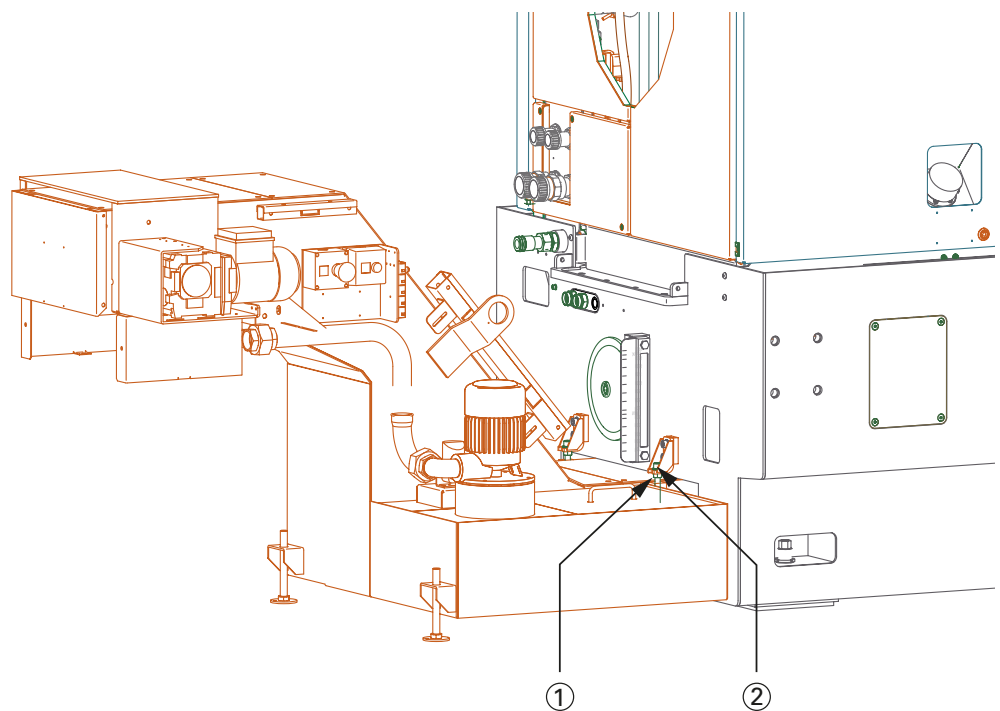

INDEX

**INDEX-Werke GmbH & Co. KG
Hahn & Tessky**

Plochinger Straße 92
D-73730 Esslingen

Fon +49 711 3191-0
Fax +49 711 3191-587

info@index-werke.de
www.index-werke.de